



INSTALLATION MANUAL FOR ROOM AIR CONDITIONER (Split Wall-Mounted Type)

INSTALLATION PRECAUTIONS

- Please read this installation manual carefully before operating the unit to ensure correct installation.
- If the power cord is damaged, replacement work shall be performed by authorised personnel only.
- This appliance is not intended for use by persons (including children) with reduced physical, sensory or mental capabilities, or lack of experience and knowledge, unless they have been given supervision or instruction concerning use of the appliance by persons responsible for their safety.
- Children should be supervised to ensure that they do not play with the appliance.
- All the pictures in the instructions are for explanation purposes only. The actual shape should prevail.
- The design and specifications are subject to change without prior notice for product improvement. Consult with the sales agency or manufacturer for details.

SAFETY PRECAUTIONS

Incorrect installation due to ignoring instruction can cause serious damage or injury. The seriousness of potential damage or injuries is classified as either a WARNING or CAUTION.

WARNING	This symbol indicated that ignoring instructions may cause death or serious injury
CAUTION	This symbol indicated that ignoring instructions may cause moderate injury to your person, or damage to your appliances or other property.

- Do not modify the length of the power supply cord or use an extension cord to power the unit
- Do not share the electrical outlet with other appliances. Improper or insufficient power supply can cause fire or electrical shock.



When connecting refrigerant piping do not let substances or gases other than the specified refrigerant enter the unit. The presence of other gases or substances will lower the unit's capacity and can cause abnormally high pressure in the refrigeration cycle. This can cause explosion and injury.

- Do not allow children to play with the air conditioner. Children must be supervised around the unit at all times.

- Installation must be performed by an authorized dealer or specialist. Defective installation can cause water leakage, electrical shock, or fire or according to the installation instructions.
- Contact an authorized service technician for repair or maintenance of this unit
- Only use the included accessories, parts, and specified parts for installation. Using non-standard parts can cause water leakage, electrical shock, fire, and can cause the unit to fail.
- Install the unit in a firm location that can support the unit's weight if the chosen location cannot support the unit's weight, or the installation is not done properly, the unit may drop and cause serious injury and damage.
- The appliance shall be stored in a room without continuously operating ignition sources (for example: open flames, an operating gas appliance or an operating electric heater) B. Do not pierce or burn.
- Appliance shall be stored in a well-ventilated area where the room size corresponds to the room area as specific for operation.
- Be aware that refrigerants may not contain an odour.

NOTE: Clause 5 to 7 are required for the units adopt R321R290 Refrigerant.

- For all electrical work, follow all local and national wiring standards, regulations, and the Installation Manual. You must use an independent circuit and single outlet to supply power. Do not connect other appliances to the same outlet. Insufficient electrical capacity or defects in electrical work can cause electrical shock or fire.
- For all electrical work, use the specified cables. Connect cables tightly, and clamp them securely to prevent external forces from damaging the terminal. Improper electrical connections can overheat and cause fire, and may also cause shock.
- All wiring must be properly arranged to ensure that the control board cover can close properly. If the control board cover is not closed properly, it can lead to corrosion and cause the connection points on the terminal to heat up, catch fire, or cause electrical shock.
- If the supply cord is damaged, it must be replaced by the manufacturer, its service agent or similarly qualified persons in order to avoid a hazard.

SELECT THE BEST LOCATION

Indoor Unit

- There should not be any heat source or stream near the unit.
- There should not be any obstacles blocking the air circulation.
- A place where air circulation in the room is good.
- A place where drainage can be easily done.
- A place where noise prevention is taken into consideration.
- Do not install the unit near the door way.
- Ensure the spaces indicated by arrows from the wall, ceiling, fence or other obstacles.
- There should not be any direct sunlight. If unavoidable, sunlight prevention should be taken into consideration.

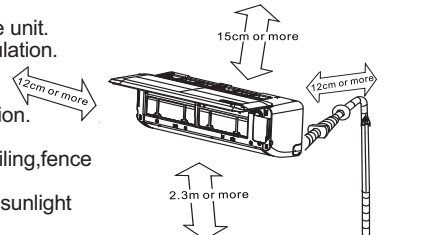

Outdoor Unit

- If an awning is built over the unit to prevent direct sunlight or rain, be careful that heat radiation from the condenser is not obstructed.
- There should not be any animal or plant which could be affected by hot air discharged.
- Keep the spaces indicated by arrow from wall ceiling, fence or other obstacles.
- Do not place any obstacles which may cause a short circuit of the discharged air.

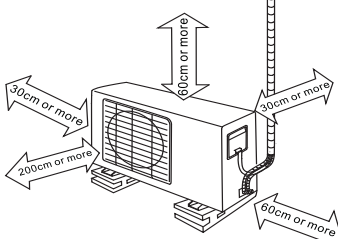

Settlement of outdoor unit

- Anchor the outdoor unit with a bolt and nut 10 or 8 tightly and horizontally on a concrete or rigid mount.
- NOTE:** The outdoor unit you purchase may be like one of the following. Install the outdoor unit according to the dimension as indicated in the table below:

Outdoor unit dimension mm (WxHxD)	Mounting dimensions	
	A (mm)	B (mm)
780x540x250	549	276
760x590x285	530	290
845x700x320	560	335
780x560x264	513	260
907x691x358	600	365

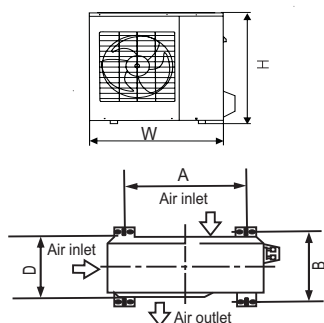

ACCESSORIES

Number	Name of Accessories	Qty		
1	Installation Plate	1		
2	Clip Anchor	5-8 (depending on models)		
3	Self-tapping Screw A ST3.9x25	5-8 (depending on models)		
4	Seal (For cooling & heating models only)	1		
5	Drain Joint (For cooling & heating models only)	1		
6	Connecting pipe Assembly	Liquid side	6.35	Parts you must purchase. The pipe size differ from appliance to appliance. Consult the technician for the proper size.
			9.52	
		Gas side	9.52	
			12.7	
7	Remote controller	1		
8	Self-tapping Screw B ST2.9x10	2		
9	Remote controller holder	1		
10	Air freshening filter (used to install on Air filter)	1 (Optional)		

NOTE: Except the above parts provided, the other parts needed during installation you must purchase.

1 INSTALLATION PLATE MOUNTING

NOTE:

- The mounting wall is strong and solid enough to prevent it from the vibration.
- Note: Standard mounting plate is model A, model B or model C, please refer to the actual unit.

Installation Plate Mounting

- Fit the installation plate horizontally on structural parts of the wall with spaces around the installation plate.
- If the wall is made of brick, concrete or the like, drill five or eight 5mm diameter holes in the wall. Insert Clip anchor for appropriate mounting screws.
- Fit the installation plate on the wall with five or eight type "A" screws.

NOTE:

Mount the Installation Plate and drill holes in the wall according to the wall structure and corresponding mounting points on the installation plate. The installation plate provided with the machine differ from appliance to appliance.

(Dimensions are in "mm" unless otherwise stated)
Correct orientation of Installation Plate

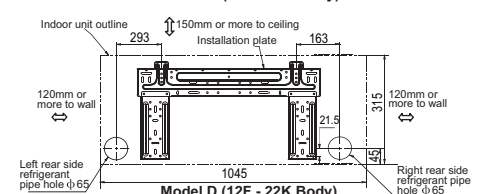
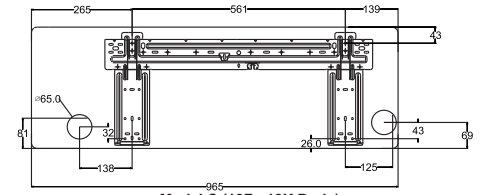
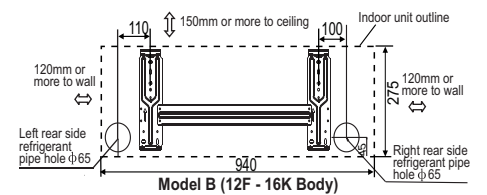
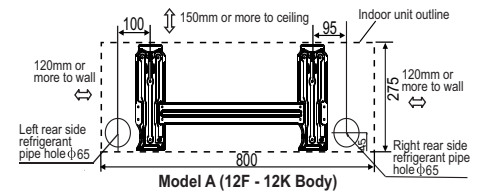
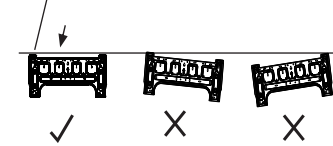

2 DRILL A HOLE IN THE WALL

- Determine hole positions according to left and right side of the installation plate. The hole center is obtained by measuring the distance as shown in the diagram above.
- Drill the piping hole with 65mm hole-core drill.
- Drill the piping hole at either the right or the left and the hole should be slightly slanted to the outdoor side.
- Always take steps to protect the pipe when drilling metal grid, metal plate or the like.

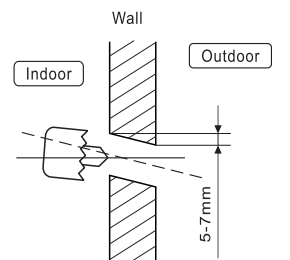

3 CONNECT THE CABLE TO THE INDOOR UNIT

Electrical work

Electric safety regulations for the initial Installation

- If there is serious safety problem about the power supply, the technicians should refuse to install the air conditioner and explain to the client until the problem is solved.
- Power voltage should be in the range of 90%~110% of rated voltage.
- The surge protector and main power switch with a 1.5 times capacity of Max. Current of the unit should be installed in power circuit. Ensure the air conditioner is grounded well.
- The appliance shall be installed in accordance with national wiring regulations. Do not operate your air conditioner in a wet room such as a bathroom or laundry room.
- An all-pole disconnection device which has at least 3mm clearances in all poles, and have a leakage current that may exceed 10mA, the residual current device (RCD) having a rated residual operating current not exceeding 30mA, and disconnection must be incorporated in the fixed wiring in accordance with the wiring rules.
- MCB shall be used as per current rating.
- According to the attached Electrical Connection Diagram located on the panel of the indoor & outdoor unit to connect the wire.
- All wiring must comply with local and national electrical codes and be installed by qualified and skilled electricians.
- An individual branch circuit and single receptacle used only for this air conditioner must be available. See the following table for suggested wire sizes and fuse specifications:

Minimum cross-sectional area of conductors:

Rated current of appliance (A)	Nominal cross-sectional area (mm ²)
>0 and <3	0.50
>3 and <6	0.75
>6 and <10	1
>10 and <16	1.5
>16 and <25	2.5

NOTE:

- The wire size of power supply cord and interconnected wire and the current of the fuse or switch are determined by the maximum current indicated on the nameplate which located on the side panel of the unit. Please refer to the nameplate before selecting the wire size, fuse or switch.
- The controller of the air conditioner designed with a fuse protection function under abnormal conditions, the specifications of the fuse have printed on the circuit board, such as: T3.15A/250VAC, T5A/250VAC, etc.

Connect the cable to the indoor unit

NOTE: Before performing any electrical work, turn off the main power to the system.

- The inside and outside connecting cable can be connected without removing the front grille.
- The indoor power cord type is H05VV-F or H05V2V2-F, the outdoor power cord and interconnected cord type is H07RN-F / As per IS-694/9968 standard.
- Lift the indoor unit panel up, remove the electrical box cover by loosening the screw.
- Ensure the colour of wires of outdoor unit and the terminal Nos. are the same to the indoor s respectively.
- Wrap those cables not connected with terminals with insulation tapes, so that they will not touch any electrical components. Secure the cable onto the control board with the cord clamp.

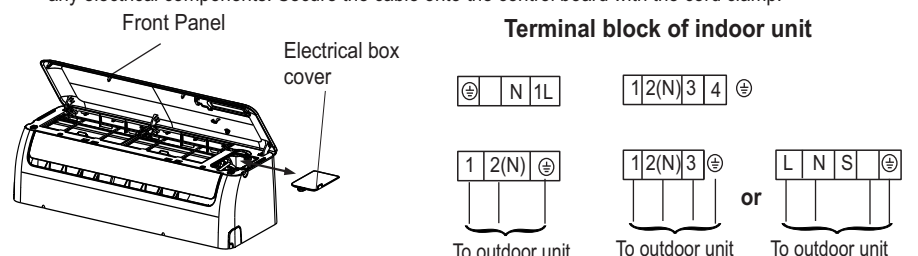

4 CONNECTIVE PIPE AND DRAINAGE INSTALLATION

Drainage

- Run the drain hose sloping downward. Do not install the drain hose as illustrated in wrong figures.
- When connecting extension drain hose, insulate the connecting part of extension drain hose with a shield pipe, do not let the drain hose slack.

